



OWL™

Microwave Motion & Infrared Presence Sensor



Instruction Manual

The OWL is a vehicle motion and presence sensor that utilizes microwave and infrared technology to activate automatic doors and industrial gates. The OWL's microwave sensor detects moving vehicles, while the infrared presence sensor can detect vehicles and pedestrians. The sensor features two relay outputs, one for vehicle motion detection, and the other for presence detection. The OWL features settings for fine-tuning the presence detection area, direction detection, hold time, and more.

The OWL-RC remote control is required for programming and servicing the OWL.

Cautions and Warnings



Install the OWL according to instructions from the door operator manufacturer. Comply with all applicable codes and safety regulations.

When drilling, ensure no damage can be caused in desired mounting location, e.g. hidden wires, waterlines, etc.

Specifications

Mounting Height	11.5-21.3 ft (3.5-6.5 m)
Supply Voltage	12-24 VDC/AC
Max Current Draw	150 mA @ 12 VDC
Operating Temperature	-4 to 140°F (-20 to 60°C)
Operating Humidity	Below 80%
Dimensions	9" (229 mm) x 5" (127 mm) x 5" (127 mm)
Connection	32 ft (10 m) 8 conductor cable directly from sensor
Weight	2.87 lbs (1.3 kg)
Environmental Rating	IP65
Vertical Directionality	16-32° wall or ceiling mount
Horizontal Directionality	±10°

	Microwave (Vehicle Motion)	Infrared (Presence)
Operating Frequency	24.150 GHz	
Detection Range	Depends on sensor height and housing angle Max. Range: 23 ft (7 m) Max. Width: 19.7 ft (6 m)	Depends on sensor height and housing angle Max. Range: 18 ft (5.5 m) Max. Width: 26.2 ft (8 m)
Relay Output	NO or NC (adjustable)	NO or NC (adjustable)
Relay Contact Rating	Max. 48 VDC Max. 300 mA	Max. 48 VDC Max. 300 mA
Relay Hold Time	Typ. 500 ms	Presence (30 sec to Infinite, adjustable)
Adjustable Tilt Angle	-10 to 25°	

Ordering Information

- OWL Vehicle Motion and Presence Sensor, includes 32 ft (10 m) of cable and two mounting screws
- OWL-RC Remote control, required for programming the OWL

Components and Indicators

OWL

1. Indicator LEDs
2. Hinge Screw
3. Angle Indicator
4. Mounting Bracket
5. Right Infrared Array
6. Microwave Tilt Adjustment Screw
7. Left Infrared Array

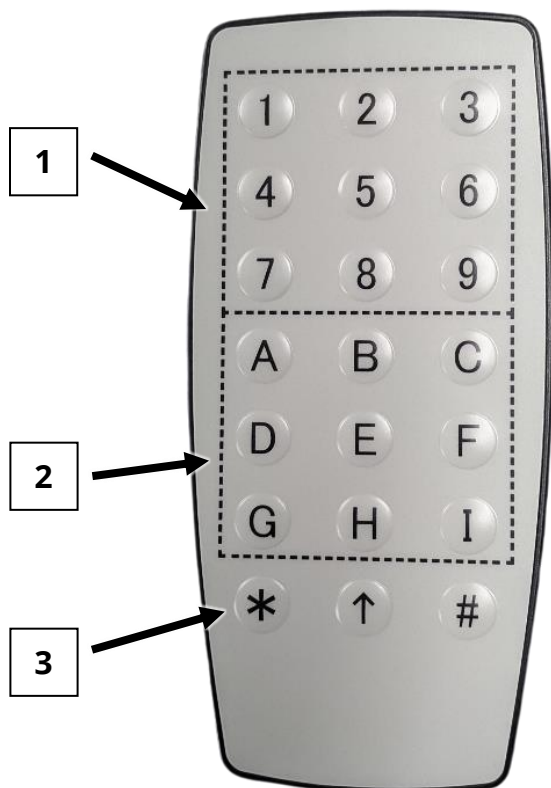
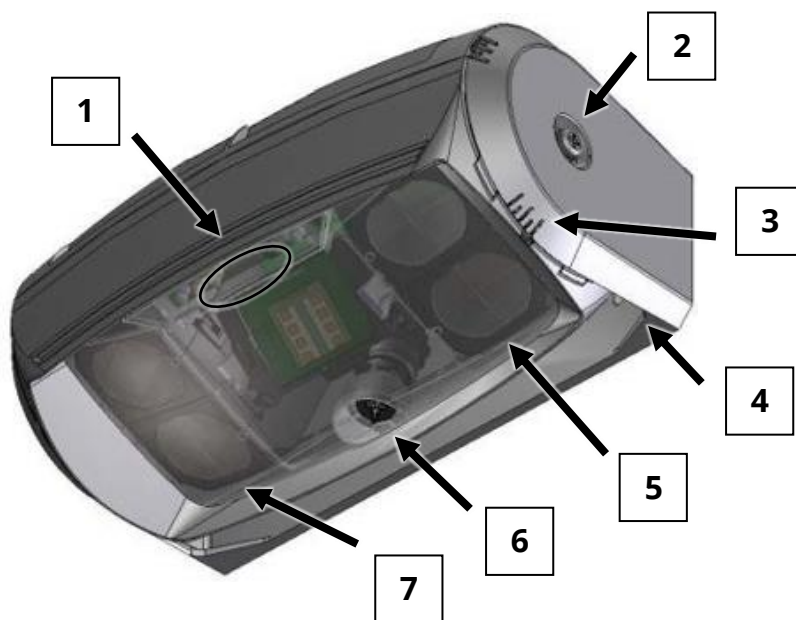

OWL-RC

1. Setting Select Buttons (**1** thru **9**)
2. Function Select Buttons (**A** thru **I**)
3. Command Buttons (**#** **↑** *****)

Installation

1. Unscrew the Philips-head hinge screws from the left and right side. Remove the sensor from the mounting bracket.
2. In the desired location, install the mounting bracket at a height between 11.5 and 21.3 ft (3.5 and 6.5 m). Drill 1/8" (3.5 mm) mounting holes as shown in the diagram and attach with the provided screws.

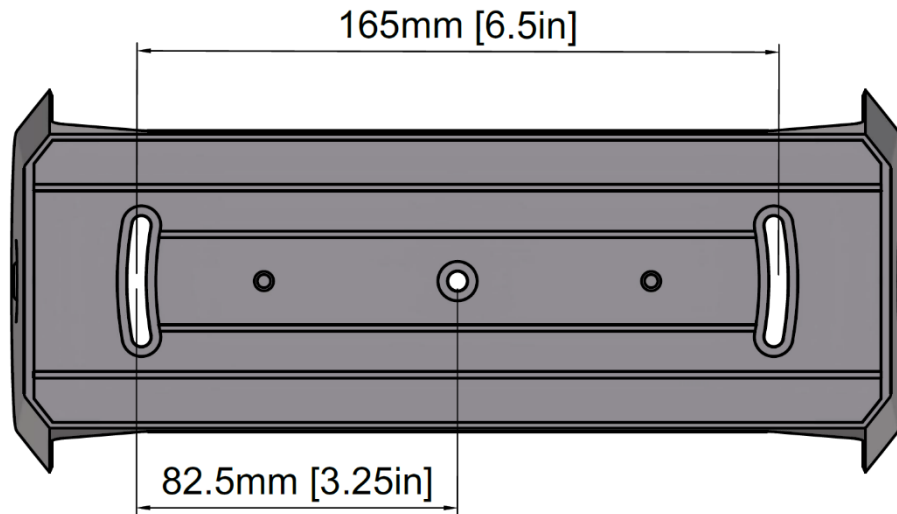

3. Re-attach the sensor to the mounting bracket using the Philips-head hinge screws from Step 1. Adjust to the desired angle, and tighten the hinge screws until snug.

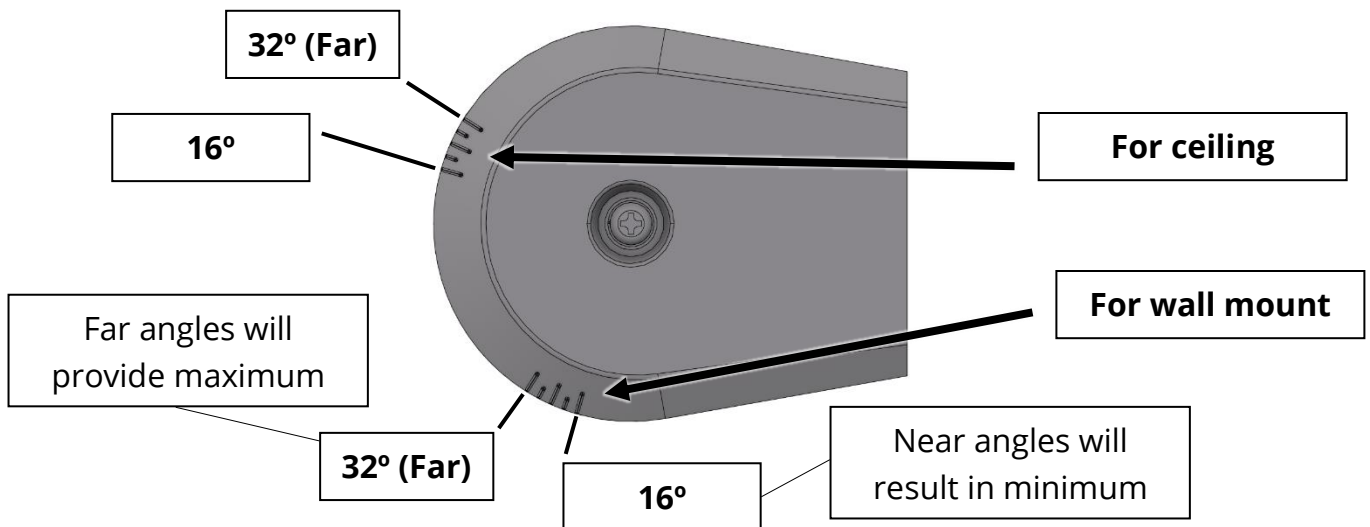

4. Wire the OWL to the door operator per the wiring table below.

Wire Color	Description
Red	Power input + (12 to 24 VDC/VAC)
Black	Power input - (12 to 24 VDC/VAC)
White	Presence relay
Green	Presence relay
Yellow	Vehicle motion relay
Blue	Vehicle motion relay
Gray	Do not connect
Brown	Do not connect

5. Apply power and allow 10 seconds for unit to stabilize. The green LED will be flashing during this time. Once stabilized (solid green LED), the sensor is operating, and the settings can now be configured.

LED Indicators

Green flashing	Sensor initialization
Green on	Standby
Red on	Presence output activated
Red flashing	Vehicle motion output activated
Yellow	Infrared sensor is detecting door movement
Green/Red flashing	Internal sensor error

Instructions continue on next page

Vehicle Motion Detection

The OWL's microwave sensor will only detect moving vehicles (cars, forklifts, etc.). When a moving vehicle is detected, it will activate the vehicle motion output relay. If the microwave sensor is detecting people, lower the microwave sensitivity.

The microwave sensor's detection area may be changed by adjusting the angle of the sensor in the bracket, changing the tilt angle of the module inside the sensor, or configuring the microwave sensitivity setting (**D**).

The microwave sensor can also be configured to ignore all cross traffic (vehicles moving parallel to the door) and departing vehicles (see Programmable Parameters on page 7).

Presence Detection

The OWL uses a pair of 6 x 5 infrared LED arrays to detect the presence of vehicles and people. When detection occurs, it will activate the presence output relay.

The presence output of the OWL is initially triggered by motion. The amount of motion required to trigger presence detection is controlled by the infrared sensitivity setting (**E**). The higher the setting, the less motion required to activate the presence detection and output. Once triggered, the output will remain on until the object(s) being detected leave the detection area, or until the configurable presence timer has run out (at which time the presence sensor will relearn the environment).

The detection area can be changed by adjusting the angle of the sensor in the bracket, or by configuring the infrared LED array settings. The farthest rows of the infrared LED array may be turned off sequentially. The outside columns of the infrared LED array may be turned off in pairs on the left and right side of the array.

The OWL's infrared presence sensor can be set to detect vehicles only, ignoring pedestrian traffic (**F**). The sensor can distinguish between the two based on the amount of light diffused.

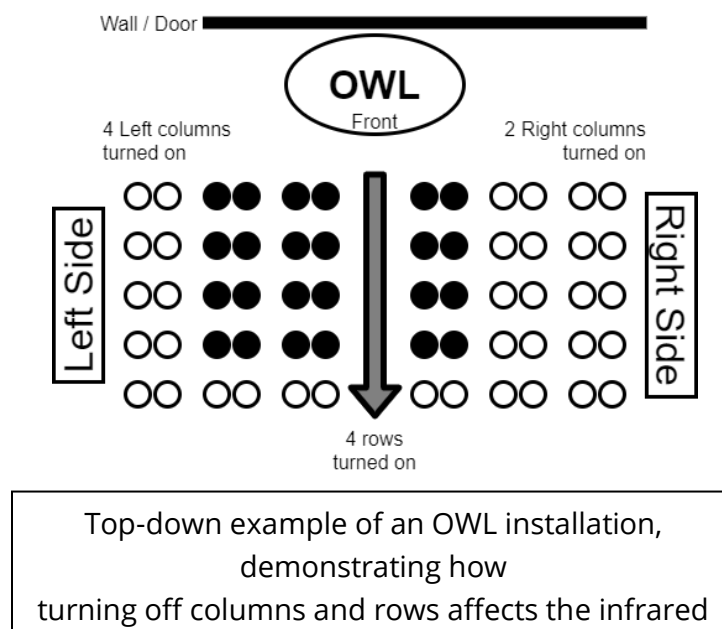

Programming the OWL

1. If a security code has been programmed on the sensor, then it must be entered before settings can be changed. Unlock the sensor by pressing the **I** button, then entering the four-digit security code, and press the enter button (**#**).

Unlock Sensor

Function	Four-Digit Security Code	Enter
I	1 - 9 1 - 9 1 - 9 1 - 9	#

2. To change a setting, point the end of the remote at the sensor, and press the button of the function to be changed. The green LED on the front of the sensor will turn off, and other LEDs on the front of the sensor will turn on.

3. Press one of the possible setting value options (**1** thru **9**). The green LED on the front of the sensor will flash the same number of times as the setting selected.

TIP: Not all functions use **1** thru **9** as a valid range of setting values. Please see page 7 for more information.

4. Press the enter button (**#**). The green LED on the front of the sensor will flash four times.

TIP: Make sure there are no vehicles in the presence detection area when saving a setting. The sensor's infrared sensor relearns the environment when a setting is saved. If there is a vehicle in the presence detection area while it relearns the environment, then the presence output will lock on when the vehicle moves.

Programming Settings

Function	Setting Value	Sensor Output	Finish
A thru I ↑ A thru ↑ I	1 thru 9	Green LED on front of sensor will flash 6 times to confirm	#

5. Wait for the sensor to save the setting and relearn the environment. Programming is now finished.

Programmable Parameters

Setting Value

Button	①	②	③	④	⑤	⑥	⑦	⑧	⑨
--------	---	---	---	---	---	---	---	---	---

Configure Relays – Set relay behavior (Presence/Motion)

A	NO/NO	NO/NC	NC/NO	NC/NC					
----------	-------	-------	--------------	-------	--	--	--	--	--

Direction Detection – Prevents sensor from detecting objects moving away from it

B	off	IR and Microwave	IR	Microwave					
----------	------------	------------------	----	-----------	--	--	--	--	--

Cross Traffic – Prevents sensor from detecting objects moving parallel to the door

C	off	IR and Microwave	IR	Microwave					
----------	------------	------------------	----	-----------	--	--	--	--	--

Microwave Motion Sensitivity – Higher sensitivity increases area of detection

D	1 (Low)	2	3	4	5	6	7	8	9 (high)
----------	---------	---	---	---	----------	---	---	---	----------

IR Presence Sensitivity – Higher sensitivity lowers threshold of detection

E	1 (Low)	2	3	4	5	6 (High)			
----------	---------	---	---	----------	---	----------	--	--	--

IR Rows – Adjusts which IR LED rows are on (see next page)

F	1 row	2 rows	3 rows	4 rows	All rows				
----------	-------	--------	--------	--------	-----------------	--	--	--	--

IR Columns, Left Side – Adjusts which left-side IR columns are on (see next page)

G	None	2	4	All					
----------	------	---	---	------------	--	--	--	--	--

IR Columns, Right Side – Adjusts which right-side IR columns are on (see next page)

H	None	2	4	All					
----------	------	---	---	------------	--	--	--	--	--

IR Frequency – Change when multiple sensors are installed near each other to prevent interference

↑ A	A	B	C	D					
------------	----------	---	---	---	--	--	--	--	--

Presence Timer – Detection time before presence sensor relearns the local environment

↑ B	30s	1min	2min	5min	10min	20min	1hr	2h	Never
------------	------------	------	------	------	-------	-------	-----	----	-------

Insect Mode – Reduce false detections from insects and other small objects

↑ C	off	On							
------------	------------	----	--	--	--	--	--	--	--

Snow Mode – Reduces false detections due to snow. When set to Auto, will turn on below 40°F (4°C)

↑ D	off	Low	Med.	High	Low Auto	Med. Auto	High Auto		
------------	------------	-----	------	------	----------	-----------	-----------	--	--

Vibration Mode – Reduces false detections due to vibrations

↑ E	off	On							
------------	------------	----	--	--	--	--	--	--	--

IR Detection Target – Configure IR to detect people and vehicles, or vehicles only

↑ F	People & Vehicles	Vehicles only							
------------	------------------------------	---------------	--	--	--	--	--	--	--

Default settings are bolded and colored in

Direction Detection and Cross Traffic functions will not work if any IR rows or columns are turned off

Left/Right columns are relative to the front of the sensor (see next page)

Additional Functions and Information

Details – IR Rows & Columns

Button	Setting Value				
	①	②	③	④	⑤

IR Rows – Adjusts which IR LED rows are on; turns off rows furthest from sensor first

F					
----------	--	--	--	--	--

IR Columns, Left Side – Turn on/off IR columns in pairs

G					
----------	--	--	--	--	--

IR Columns, Right Side – Turn on/off IR columns in pairs

H					
----------	--	--	--	--	--

○ = Off ● = On

Reading Settings

Start	Desired Function	Enter	Sensor Output	Finish
* (up arrow)	A thru H (up arrow) / A thru F (up arrow)	#	Green LED on front of sensor will flash 1-9 times, confirming the function setting value	#

Maintenance Mode

Start	Options				Enter
(up arrow) H	①	②	③	④	#
	Activate output relays indefinitely	Cancel output relays activation	Return to factory settings	Reset sensor	

Note: LEDs on front of sensor will act as below when outputs are turned on using Maintenance Mode

Blue: Solid **Yellow:** Off **Red:** Flashing

Security Code

Function	Button	Enter 4 Digit Code	Enter Button
Set Security Code	(up arrow) I	1 - 9 1 - 9 1 - 9 1 - 9	#
Unlock Sensor	I	1 - 9 1 - 9 1 - 9 1 - 9	
Delete Security Code	(up arrow) I	9 9 9 9	

Note: When unlocked, settings may be changed for 60 seconds. The timer stops while a setting is being configured. The timer extends for 60 more seconds after a setting has been entered.

Note: To reset or delete the security code, power cycle the unit. The unit will not require a security code for 60 seconds after power-up. Use the "Delete Security Code" function above, then set a new security code.

LED Indicators

While programming the sensor, the three indicator LEDs will turn on, off, or flash based on what function is being configured. Below is a table to show which functions correspond to the states of the three LEDs.

○ = Solid ☀ = Flashing

Function	Button	Blue	Yellow	Red
Read Setting	⌘	●		
Up Arrow Button	↑	☀		
Enter	#	●	☀	☀
Configure Relays	A			●
Direction Detection	B		●	
Cross Traffic	C		●	●
Microwave Motion Sensitivity	D			☀
IR Presence Sensitivity	E		☀	
IR Rows	F		☀	☀
IR Columns, Left Side	G		●	☀
IR Columns, Right Side	H		☀	●
IR Frequency	↑ A	☀		●
Presence Timer	↑ B	☀	●	
Insect Mode	↑ C	☀	●	●
Snow Mode	↑ D	☀		☀
Vibration Mode	↑ E	☀	☀	
IR Detection Target	↑ F	☀	☀	☀
Maintenance Mode	↑ H	☀	●	☀
Relays Activated Indefinitely		●	●	☀
Setting Security Code	↑ I	☀	☀	●
Unlocking Security Code	I	●	●	
Security Code Unlocked		●	●	●

Troubleshooting

Symptom	Possible Cause	Solution
No LEDs on	No power or faulty power connection	<ol style="list-style-type: none"> 1. Verify the voltage is between 12-24 VDC or 12-24 VAC using a digital multimeter. 2. Verify wires are terminated properly. 3. If voltage is present and there are still no LEDs on, the sensor is defective.
Door is detected	Sensor is angled toward door	<ol style="list-style-type: none"> 1. Adjust the sensor housing away from the door. 2. Reduce the microwave and/or infrared sensitivity settings. 3. Adjust the microwave tilt angle.
	Vibrations	Turn on Vibration Mode.
Remote control does not respond	Device is locked	Cycle power to the sensor. The sensor can now be configured without a code for 60 seconds.
	Batteries are low	Replace batteries with two AAA batteries (in cold weather, battery life can be reduced).
Person is mistaken for a vehicle	Microwave sensitivity is set too high	Lower the microwave sensitivity setting.
	Sensor is mounted too low	Mount sensor higher, 11.5 to 21.3 ft (3.5 to 6.5 m) from the ground.
Object is detected too late	Microwave or infrared sensitivity is set too low	Increase the microwave and/or infrared sensitivity setting.
	Sensor aimed too low	Adjust the aim of the sensor
	Infrared rows turned off	Change the infrared rows setting (F)
False activation	Vibrations, water, metal, or non-stationary object in the sensor's environment	<ol style="list-style-type: none"> 1. Decrease the microwave and/or infrared sensitivity setting. 2. Remove the non-stationary object from the detection area 3. Install something to prevent rain from interfering with the sensor
	Rain	
Sensor not detecting	Sensor installed too high	Mount the sensor lower, 11.5 to 21.3 ft (3.5 to 6.5 m) from the ground.
	Too cold	Sensor is not suitable for use in temperatures below -4°F (-20°C).

Warranty

EMX Industries, Inc. products have a warranty against defects in materials and workmanship for a period of two years from date of sale to our customer.